

Einpresstechnik gewinkelt 90°, 9.4 mm

Gedrehte Kontakte / Bauhöhe 7.4 mm

90° Press-Fit technology, 9.4 mm

Machined contacts / Mounting height 7.4 mm

Stiftleiste

Plug connector

Buchsenleiste

Socket connector

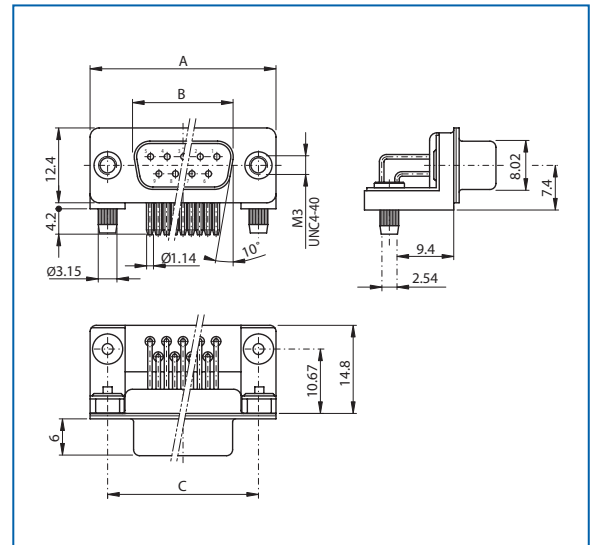
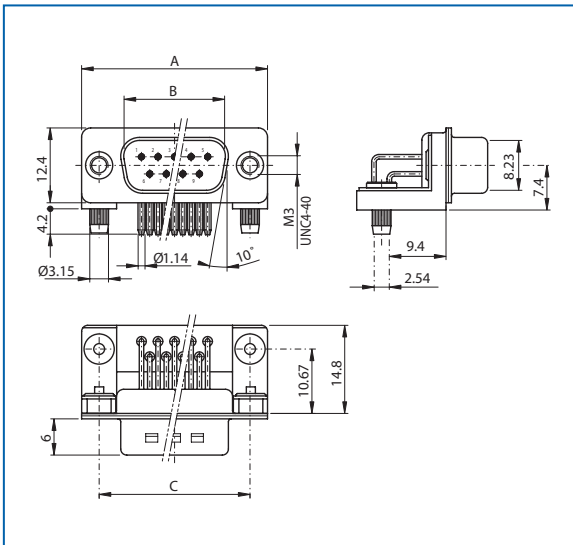

Polzahl

No. of pos.	A	B	C
09	30.80	16.79	25.00
15	39.20	25.12	33.30
25	53.10	38.84	47.00
37	69.50	55.30	63.50

Polzahl

No. of pos.	A	B	C
09	30.80	16.46	25.00
15	39.20	24.79	33.30
25	53.10	38.50	47.00
37	69.50	54.96	63.50

Bestellbezeichnung

Polzahl	Gehäuse chromatiert	Gehäuse verzinkt
No. of pos.	Chromated shell	Tinned shell
09		DTS 09 PYC PFF x
15		DTS 15 PYC PFF x
25		DTS 25 PYC PFF x
37		DTS 37 PYC PFF x

Order information

Polzahl	Gehäuse chromatiert	Gehäuse verzinkt
No. of pos.	Chromated shell	Tinned shell
09		DTS 09 SYC PFF x
15		DTS 15 SYC PFF x
25		DTS 25 SYC PFF x
37		DTS 37 SYC PFF x

Anstelle des x am Ende der Artikelbezeichnung die gewünschte Güteklasse 1 oder 2 einfügen.
Andere Vergoldungen auf Anfrage.

To request class 1 or 2 quality, replace the x at the end of the part no.
Other gold plating on request.

Montagen am Ende des Kapitels
Assemblies at the end of the chapter